

S7225

2011-2014 Ford Mustang GT, 5.0L,
Axle-Back, 3.0" Dual Split Rear

MBRP®

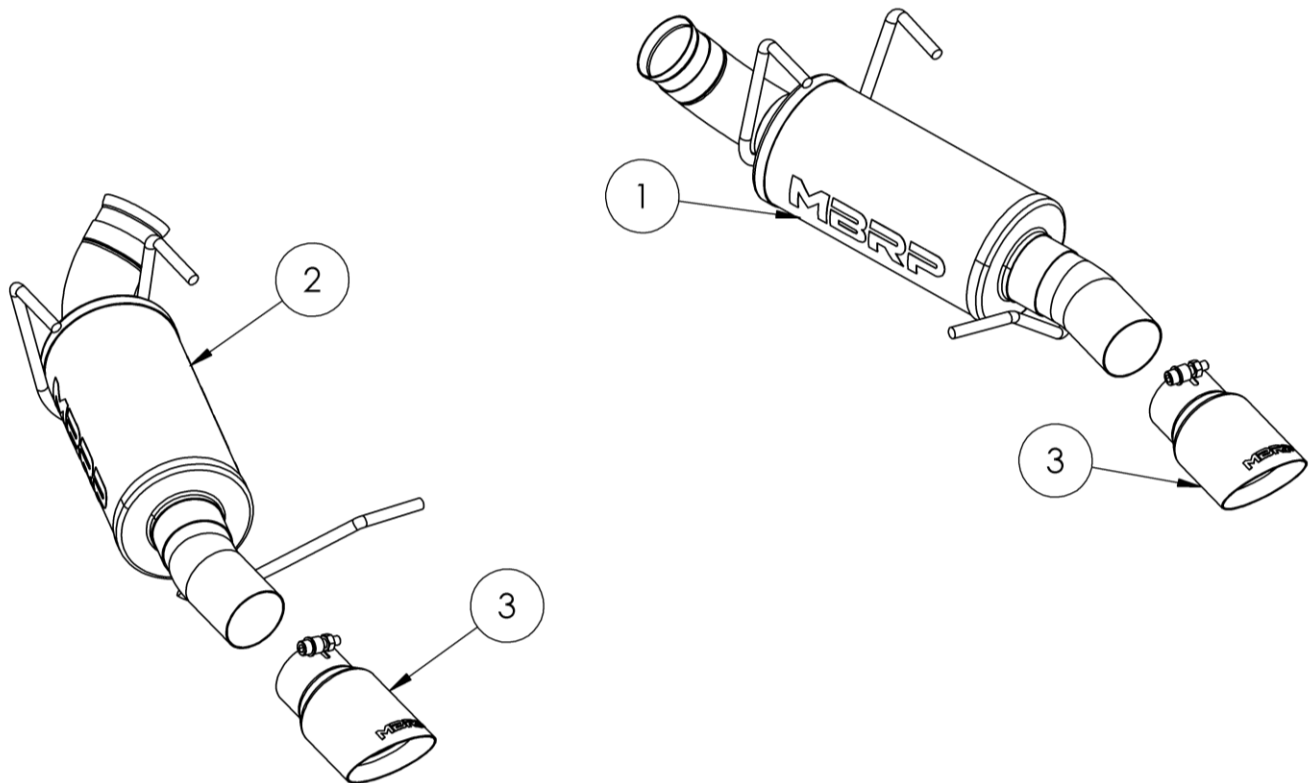

1. PASSENGER-SIDE MUFFLER ASSSEMBLY
2. DRIVER-SIDE MUFFLER ASSSEMBLY
3. EXHAUST TIP (2 PCS)

PLEASE READ BEFORE STARTING INSTALLATION

While MBRP has made every effort to ensure that all components of this system are of superior quality and properly packaged, it is the installer's responsibility to ensure the following before removal of the factory exhaust:

- that ALL components shown above are present.
- that ALL mating components fit together.
- that there are no damaged components.
- that the system you have purchased is appropriate for your vehicle year, model and configuration.
- that the system will not interfere with any modifications previously installed or planned.
- that you have read and understand these instructions.

If you have any questions or are uncertain about any aspect of the installation of this system to your vehicle please contact your dealer before commencing installation.

Removal of Stock Mufflers



Figure 1

1. Loosen the OEM band clamp at the muffler inlet joint on both mufflers. Refer to Figure 1.

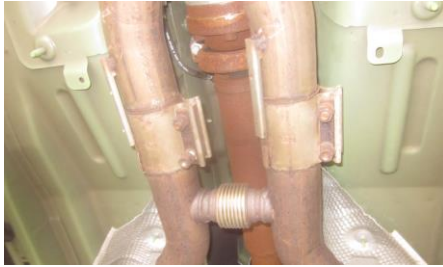

Figure 2

2. Loosen the OEM band clamps at the inlets of the over axle pipes. Refer to Figure 2.

3. Remove the two bolts connecting the cross brace to the frame and lower the cross brace to make room for the muffler to slide forward.

Refer to figure 3.

4. Remove the rear muffler hanger from the rubber isolator. Lift up the front pipes and slide the muffler toward the front of the car to remove from the front hangers. Repeat for the other side.

Refer to Figure 4.

(Alternative method remove hanger mounts and slide muffler to the rear of the car)



Figure 3

Installation of MBRP Inc. Performance Exhaust:

1. Remove the OEM band clamp from the OEM Muffler assemblies by cutting the retaining bracket. Slide the OEM clamps onto the **Muffler Assemblies**. Refer to Figure 5.

2. Install the **Driver-Side Muffler Assembly** by aligning the 2 front hangers with the rubber mount on the car. Insert the hangers by sliding the **Driver-Side Muffler Assembly** toward the rear of the car. Lift the rear of the delete pipes and install the rear rubber isolator.

Refer to Figure 6.

3. Position the over axle pipe into the **Muffler Assemblies** and secure with the OEM band clamp. Ensure the connections are fully seated before tightening the clamps.

4. Repeat for Passenger-side.

5. Re-install the cross-brace and tighten the OEM band clamps at the inlets of the over axle pipes.

6. Install the supplied **Tips** and tighten all hardware and clamps, starting at the front and working rearward to secure the system. Check along the full length of the exhaust system to ensure there is adequate clearance for fuel lines, vent lines, brake lines, frame, bodywork, suspension, and any wiring, etc. If there is any interference detected, relocate, or adjust to provide adequate clearance. Ensure all clamp connections are secure and components are unable to rotate or slide. Band clamps require approximately 45 lb-ft (60 N-m) of torque. Verify clearances, system security and band clamp torque after 30-60 miles (50-100 km) of driving.



Figure 4



Figure 5



Figure 6

MBRP[®]



Congratulations! You are ready to begin experiencing the improved power, sound and driving excitement of your MBRP Inc. performance exhaust system. We know you will enjoy your purchase.